

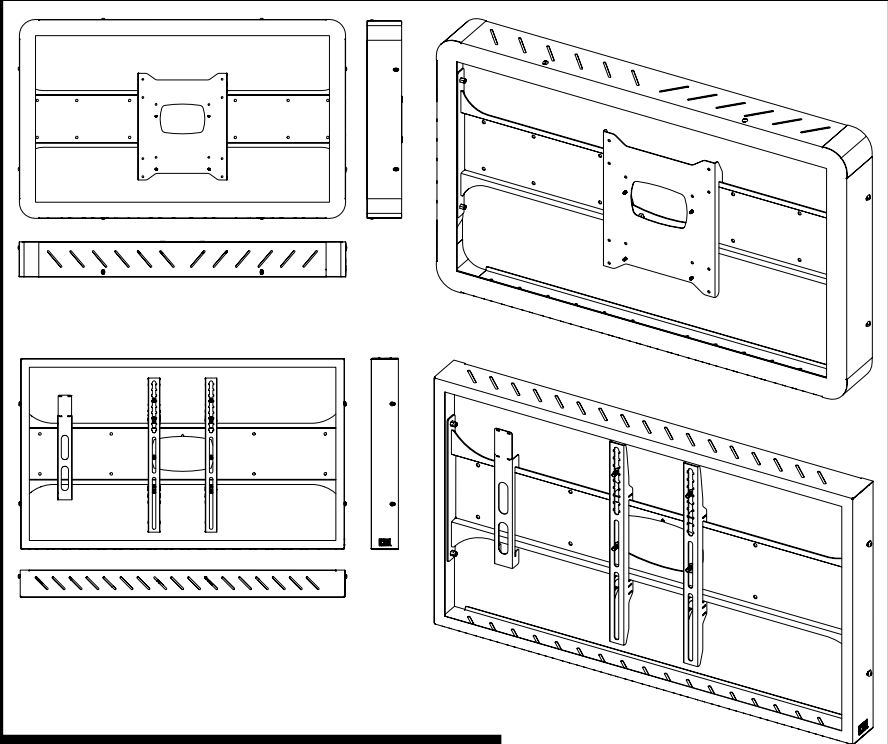

## Wall Mounted Protective Covers PCL / PCP 5, 7, 8, 9, 10, 11, 12, 13



**Screen Size:** 15-75" | **Guide Max. Weight:** 60kg

\*Please check model specific details before installing\*

Revised 12/04/24

### WARNING

Please carefully inspect the product before assembling. If you notice any apparent damage, call your carrier claims agent and do not continue the installation until it has been reviewed. Please watch for pinch points. Do not put your fingers between moveable parts. Do not tamper with or disassemble any spring loaded parts. Before installing, make sure that the supporting surface will support five times the combined load of the solution and the hardware. Never exceed the maximum load capacity. Please also layout all components to ensure that you have all of the required parts before proceeding (see BOM list on following page). Use of this product for anything other than its specified use may result in failure or personal injury. This product is intended for indoor use only. We recommend using a qualified trades person for installation. Use an assistant or lifting equipment to lift and position products.

For support, please call: +44 (0)1865 767676 or email: sales@unicol.com



#	TOOLS REQUIRED
1	4mm & 5mm Allen Keys
2	Pozi Head Screwdriver

INSTALLERS REQUIRED
<b>1-2</b>

COMPONENTS

#	DESCRIPTION	QTY
1	Outer Protective Cover	1
2	Anti-Shatter Screen	1
3	Inner Screen Cover	1
4	Wall Mount	1
5	Dedicated Screen Mount/Arms <i>(Style May Vary)</i>	1
6	Button Head Screw M8 X 20	8

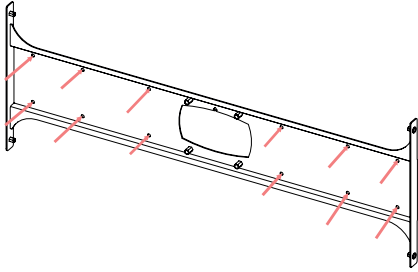

### STEP 1

Using the 8 - 12 wall mounting holes on the back plate, determine where you want to install your mount, mark it and fix into position.

*Please consider cabling and wall fixings prior to installation. Please check surface is capable of supporting 5x the combined solutions weight.*

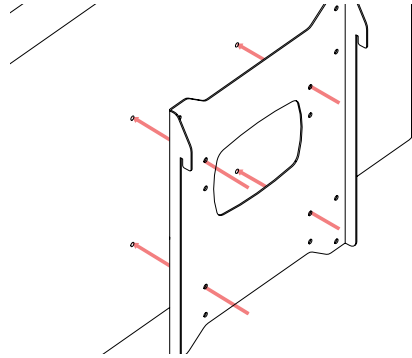

### STEP 2

Using the fixing pack provided, attach the dedicated screen mount bracket (or arms) to the back of your screen.

*Ensure that the bracket/arms are the correct way up before tightening - the hooks should be at the top as shown above.*

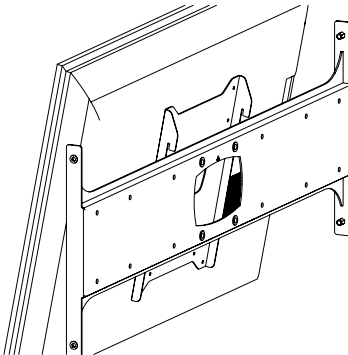

### STEP 3

Using another team member, lift the screen up and gradually offer it up to the back plate. Gently tilt the screen forward and hook the arms over lip of the wall mount. Lower the screen until it is securely in place.

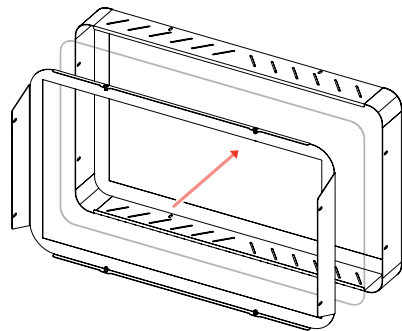

### STEP 4

Take the anti-shatter screen and gently place it into the outer protective cover. Once in place, take the inner screen cover and place that on top of the anti-shatter screen within the outer cover.

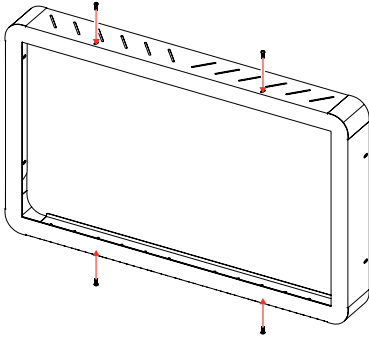

## STEP 5

Secure the inner cover by screwing into the two top and bottom fixing points. This will keep both cover halves and the anti-shatter screen securely together.

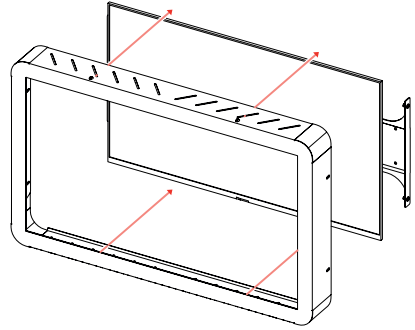

## STEP 6

Take the fully assembled cover and place it over the screen and wall mount. Ensure that the fixing holes located on the left and right sides of the cover line up with the fixing points on the sides of the wall mount.

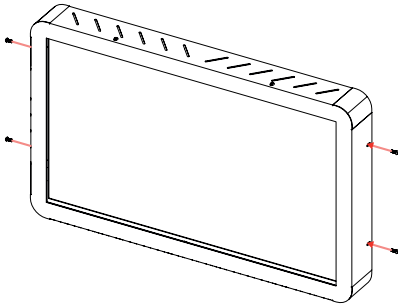

## STEP 7

Secure the protective cover by screwing into the two fixing points on the left and right of the cover. The protective cover is now securely held into place.