

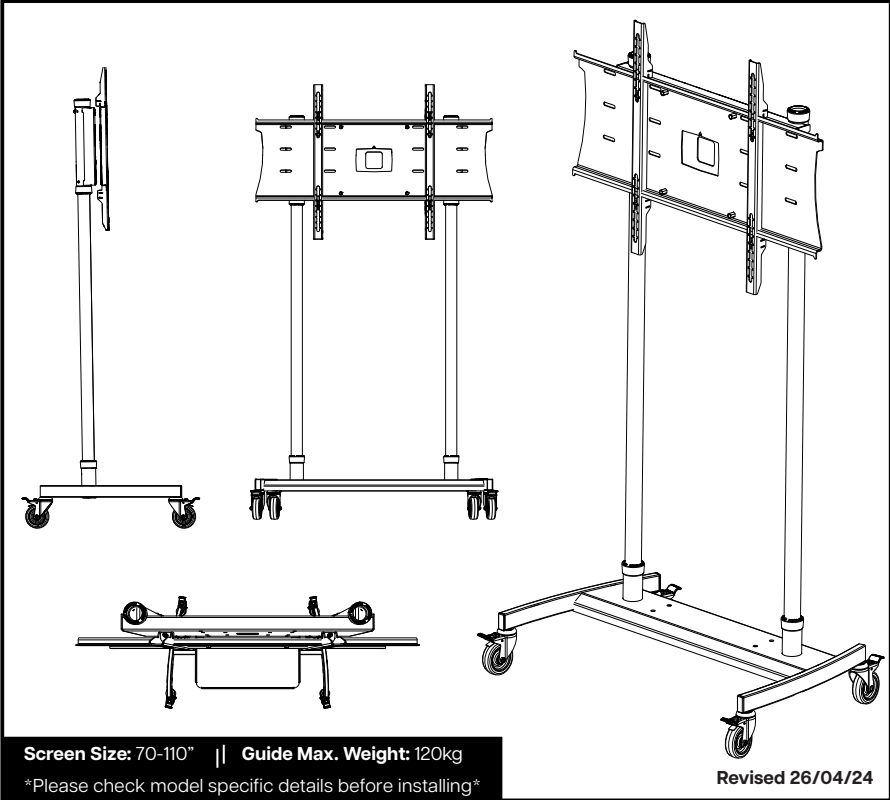

TCAVT



WARNING

Please carefully inspect the product before assembling. If you notice any apparent damage, call your carrier claims agent and do not continue the installation until it has been reviewed. Please watch for pinch points. Do not put your fingers between moveable parts. Do not tamper with or disassemble any spring loaded parts. Before installing, make sure that the supporting surface will support five times the combined load of the solution and the hardware. Never exceed the maximum load capacity. Please also layout all components to ensure that you have all of the required parts before proceeding (see BOM list on following page). Use of this product for anything other than its specified use may result in failure or personal injury. This product is intended for indoor use only. We recommend using a qualified trades person for installation. Use an assistant or lifting equipment to lift and position products.

For support, please call: +44 (0)1865 767676 or email: sales@unicol.com



#	TOOLS REQUIRED
1	4mm & 5mm Allen Keys
2	Pozi Head Screwdriver

INSTALLERS REQUIRED
1-2

COMPONENTS

1

2

3

4

5

6

7

#	DESCRIPTION	QTY
1	TCAVTB Trolley Base	1
2	1650 Columns	2
3	TCAVS Shelf (Optional)	-
4	TCAVTG Mount Adapter	1
5	PZX9 Screen Mount - Back Plate	1
6	PZX9 Screen Mount - Mounting Arms	2
7	TCVLC Cabinet (Optional)	-

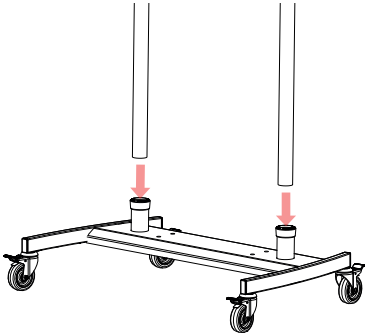

STEP 1

Place trolley base on a flat surface and apply brakes by pressing down levers on each castor. Loosen the grub screws on the back of socket upstands and place a column in each socket. Tighten grub screws until they just touch columns. Do not tighten fully.

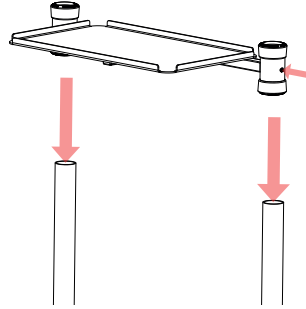

STEP 2 [optional]

If fitting the optional shelf loosen the grub screws in the shelf sockets and place over the columns. Allow shelf to rest on the trolley base for now. Do not tighten grub screws.

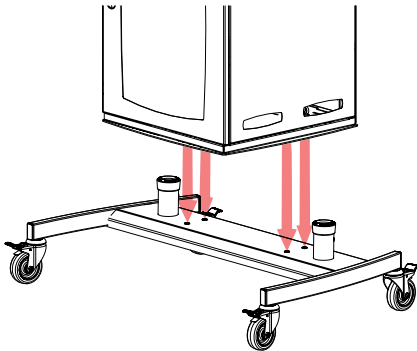

STEP 3 [optional]

If fitting the optional cabinet, allow cabinet to rest on the trolley base. Do not tighten grub screws.

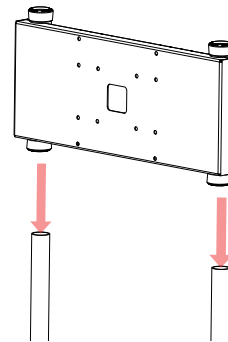

STEP 4

Loosen the grub screws in the mount adapter sockets. Place over the columns so that the column edges are level with the tops of the top socket caps. Tighten grub screws so they just stop the adapter from sliding down the columns. Do not tighten fully.

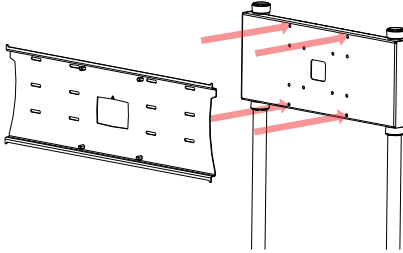

STEP 5

Fit the PZX9 backplate to the mount adapter. Secure into the backplate rivnuts with the 4 x M dome head allen screws through the 300 x 300 fixing holes in the mount adapter.

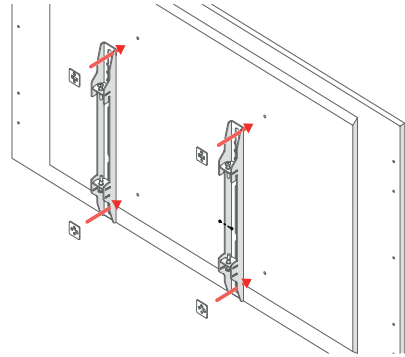

STEP 6

Using the griplock (top) and taglock (bottom) spacers fix the mount arms to the screen fixing holes. Choose the correct manufacture recommended fixing screws for your screen from the universal fixing pack supplied.

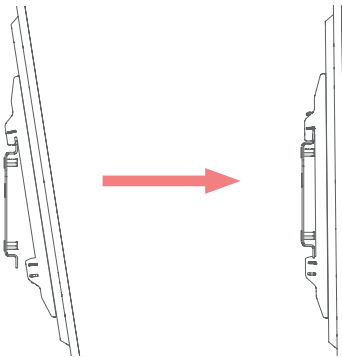

STEP 7

Using another team member, lift the screen up and gradually offer it up to the back plate. Gently tilting the screen forward, hook the arms over the lip of the back plate rail and lower once in position.

Centre the screen horizontally by sliding from side to side until you are happy with the position.

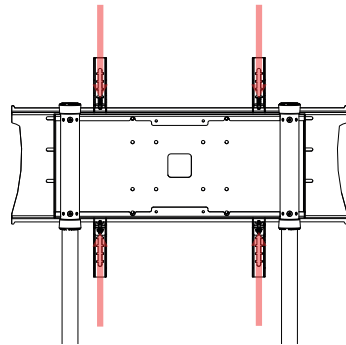

STEP 8

Once centered, ensure the bottom screws are not tightly fixed and screw down the top screws to level the screen. Once level tighten bottom screws to secure the mount.

Note that you won't be able to adjust the screens position after the screws have been tightened.