

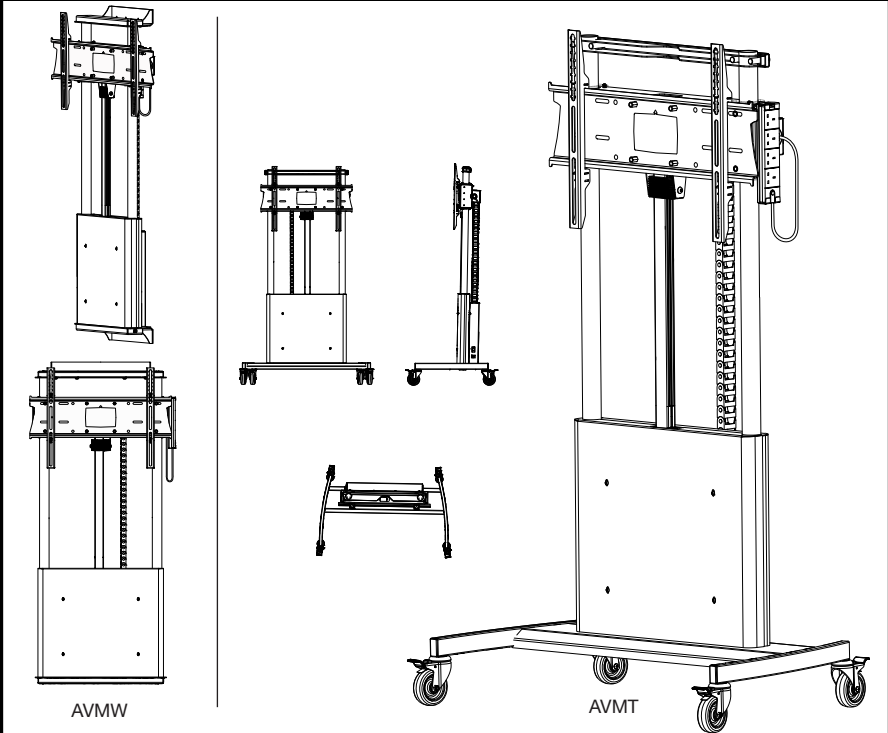

## AVMT & AVMW



AVMW

AVMT

Screen Size: 33-100" | Guide Max. Weight: 150kg

*\*Please check model specific details before installing\**

Revised 15/12/21

### WARNING

Please carefully inspect the product before assembling. If you notice any apparent damage, call your carrier claims agent and do not continue the installation until it has been reviewed. Please watch for pinch points. Do not put your fingers between moveable parts. Do not tamper with or disassemble any spring loaded parts. Before installing, make sure that the supporting surface will support five times the combined load of the solution and the hardware. Never exceed the maximum load capacity. Please also layout all components to ensure that you have all of the required parts before proceeding (see BOM list on following page). Use of this product for anything other than its specified use may result in failure or personal injury. This product is intended for indoor use only. We recommend using a qualified trades person for installation. Use an assistant or lifting equipment to lift and position products.

*For support, please call: +44 (0)1865 767676 or email: sales@unicol.com*



#	TOOLS REQUIRED
1	3/16 <sup>th</sup> Allen Key
2	Pozidrive Screwdriver
3	17mm Spanner

INSTALLERS REQUIRED
<b>1-2</b>

### COMPONENTS

#	DESCRIPTION	QTY
1	Trolley Base (AVMT only)	1
2	Powalift Module	1
3	PZX Screen Mount - Back Plate	1
4	PZX Screen Mount - Mounting Arms	2
5	Remote Control	1
6	Manual Operating Switch & cable	1
7	Top & Bottom Fixings (AVWM only)	2
8	Wall Fixing Brackets (AVWM only)	2
9	PZX9 Converter Plate (71 - 100" screens)	1
10	Optional Accessory - (AVML7 platform)	1



## AVMT – TROLLEY

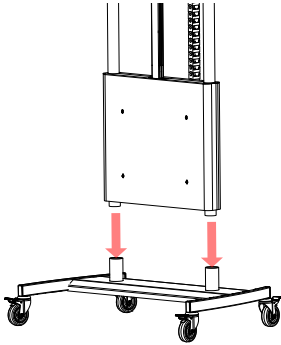

### AVMT – STEP 1

Place trolley base on a flat surface and apply brakes by pressing down levers on each castor. Loosen the grub screws on the back of socket upstands and with the help of another person place the Powalift Module into the sockets. Tighten grub screws.

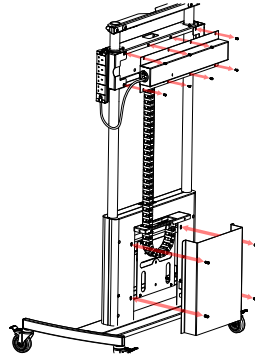

### AVMT – STEP 2

Remove the 8 x M6 x 16 socket button head screws and remove the top cable cover to gain access to the 4 x Mount Backplate fixing holes.

If you are connecting an external network cable remove the bottom cover (4 screws).

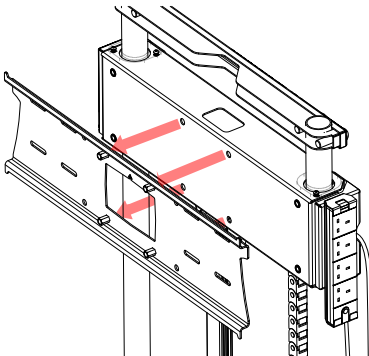

### AVMT – STEP 3

Fit the PZX backplate to the top assembly using the 4 x M10 x 25 hex-head screws through the fixing holes in the top assembly. Leave cable cover off.

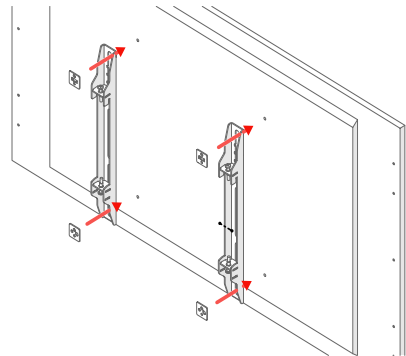

### AVMT – STEP 4

Using the griplock (top) and taglock (bottom) spacers fix the mount arms to the screen fixing holes. Choose the correct manufacture recommended fixing screws for your screen from the universal fixing pack supplied.

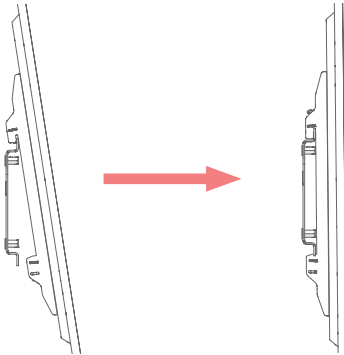

### AVMT – STEP 5

Using another team member, lift the screen up and gradually offer it up to the back plate. Gently tilting the screen forward, hook the arms over the lip of the back plate rail and lower once in position.

Centre the screen horizontally by sliding from side to side until you are happy with the position.

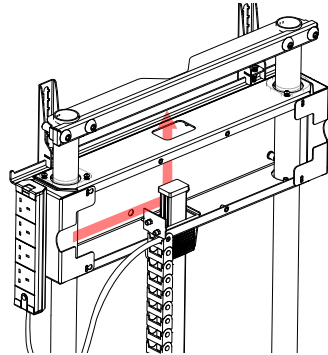

### AVMT – STEP 6

With the screen fitted, cable it up routing through the cable cover and up through aperture at rear of screen. External network cables are routed under the rear bottom cover and up through the cable train

After cabling refit the cable cover by reversing actions in Step 2.

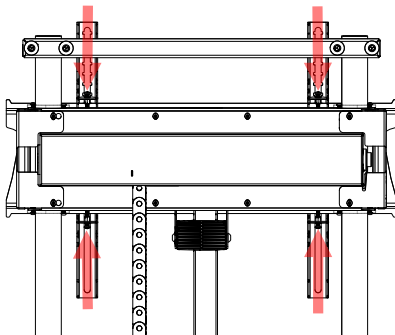

### AVMT – STEP 7

Once centered, ensure the bottom screws are not tightly fixed and screw down the top screws to level the screen. Once level tighten bottom screws to secure the mount. Connect cables to screen.

**NOTE:** The screen position cannot be adjusted after the bottom screws have been tightened.

### LIFT OPERATION

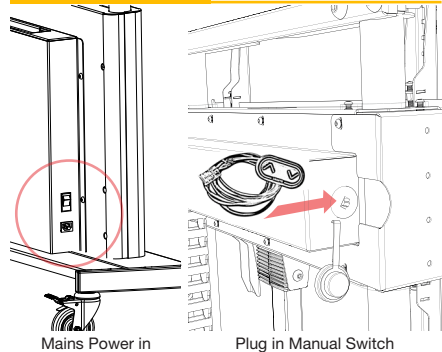

### All – STEP 1

Operate the lift motor using manual switch, hand held remote or LINAK Desk Control App. Connect mains power. Plug in manual switch press the UP arrow or DOWN arrow (hand held remote also) to operate the screen movement .

Download LINAK Desk Control App from this link: <https://www.linak.co.uk/products/controls/desk-control-app/#/description> or use QR code above.

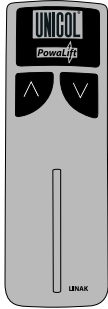

Hand Held Remote



LINAK Desk Control App



## STEP 2

As soon as power is connected you have 3 minutes to pair the App by pointing your phone at the unit. When bluetooth has connected your phone press 'Connect'. Continue to follow the instructions on the App to operate the unit.

*Note: This App was built for desks but is recommended by LINAK to operate this unit.*

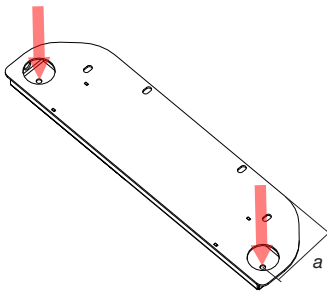

## AVMW – STEP 2

Identify floor plate, loosen grub screws to gain access to bottom holes. Measure 134mm (a) from the wall. (Consider skirtings). Mark and drill. Using suitable anchors fix floor plate.

*NOTE: The wall has to be capable of supporting 5 times the load of the combined display and unit. Therefore, it may be necessary to reinforce the floor and wall before starting this installation.*

## AVMW – FLOOR TO WALL

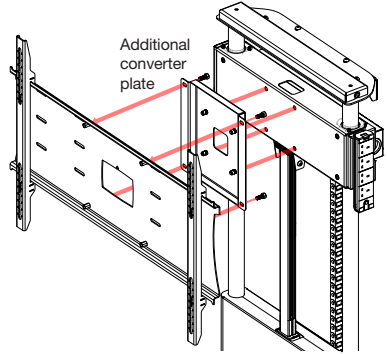

## AVMW – STEP 1

The rear of the unit is inaccessible once wall fitted so it is important to cable up first. (Do not fit screen).

When using a PZX1 or PZX3 for 33-70" screens, remove rear covers and follow AVMT Steps 2, 3 & 4.

When using a PZX9 for 71-100" screens, remove rear covers and follow AVMT Steps 2 & 4, but replace AVMT Step 3 with the above.

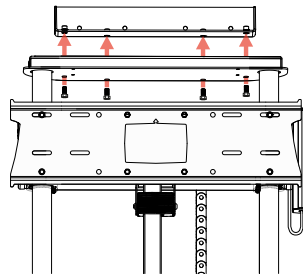

## AVMW – STEP 3

Using the 4 x M10 x 25 hex head screws loosely fix one of the wall brackets to the top plate. Discard the other wall bracket. There is a small amount of adjustment in the slots, which can be used when levelling unit in the next step.

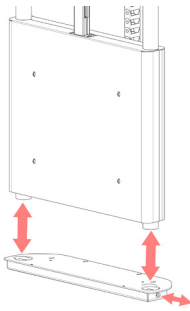

### AVMW – STEP 4

With the help of another person place the Powalift Module into the sockets. Whilst supporting the unit mark the wall for the top wall bracket fixing holes ensuring the unit is level. Lift unit out from floor plate, drill and fit suitable anchors. Refit unit to base and fix wall plate to wall (fixings not supplied). Tighten all screws in top and base.

Follow Steps 5,7 & 8 of AVMT instructions to complete installation.

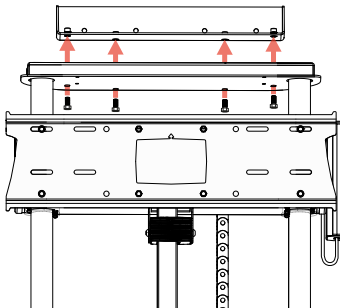

### AVMW – STEP 2

Using the 4 x M10 x 25 hex head screws loosely fix one of the wall brackets to the top plate and the other wall bracket to the bottom plate.

There is a small amount of adjustment in the slots, which can be used when levelling unit to wall.

### AVMW – WALL FIXED

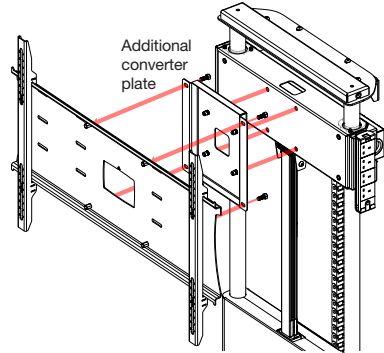

### AVMW – STEP 1

The rear of the unit is inaccessible once wall fitted so it is important to cable up first. (Do not fit screen).

When using a PZX1 or PZX3 for 33-70" screens, remove rear covers and follow AVMT Steps 2, 3 & 4.

When using a PZX9 for 71 - 100" screens, remove rear covers and follow AVMT Steps 2 & 4, but replace AVMT Step 3 with the above.

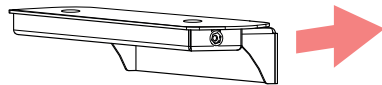

### AVMW – STEP 3

Decide the height on the wall where the bottom of the unit should be. Mark and drill. Use appropriate anchors and fix the bottom wall bracket.

**NOTE:** The wall has to be capable of supporting 5 times the load of the combined display and unit. Therefore, it may be necessary to reinforce the floor and wall before starting this installation.



## AVML7 – PLATFORM

### AVMW – STEP 4

With the help of another person place the Powalift Module into the bottom wall bracket sockets.

Whilst supporting the unit mark the wall for the top wall bracket fixing holes ensuring the unit is level.

Lift unit out from bottom plate, drill and fit suitable anchors, refit unit to base and fix top wall plate to wall (fixings not supplied). Tighten all screws in top and bottom brackets.

Follow Steps 5,7 & 8 of AVMT instructions to complete installation.

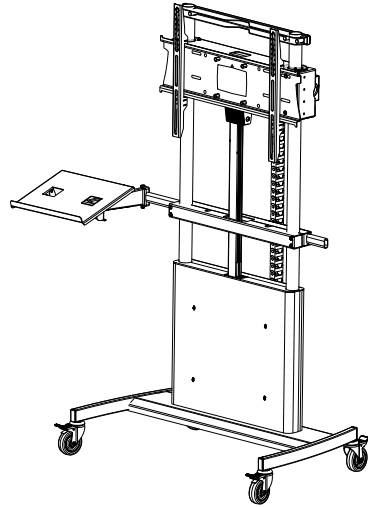
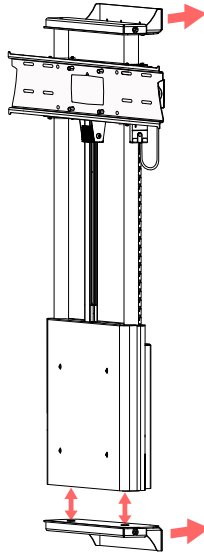

### AVML7 - Platform (OPTIONAL)

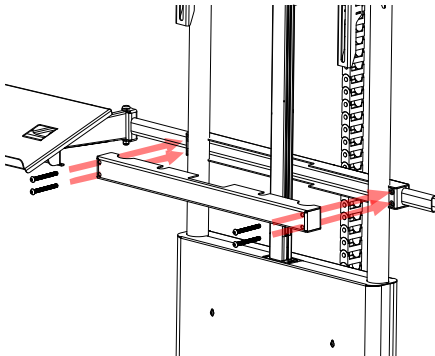

### STEP 1 (OPTIONAL)

Remove the 4 x screws that hold the front clamping cover to the Main Arm. Choose the required height of platform and refit clamp cover. Tighten the 4 x screws.

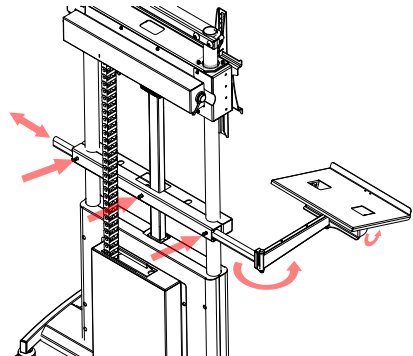

### STEP 2 (OPTIONAL)

The Platform can be adjusted in all planes. Side adjustment is attained by loosening the 3 x Allen screws at the rear of the Main Arm and sliding the arm in and out. The Small Arm can swivel and the Platform can tilt.