

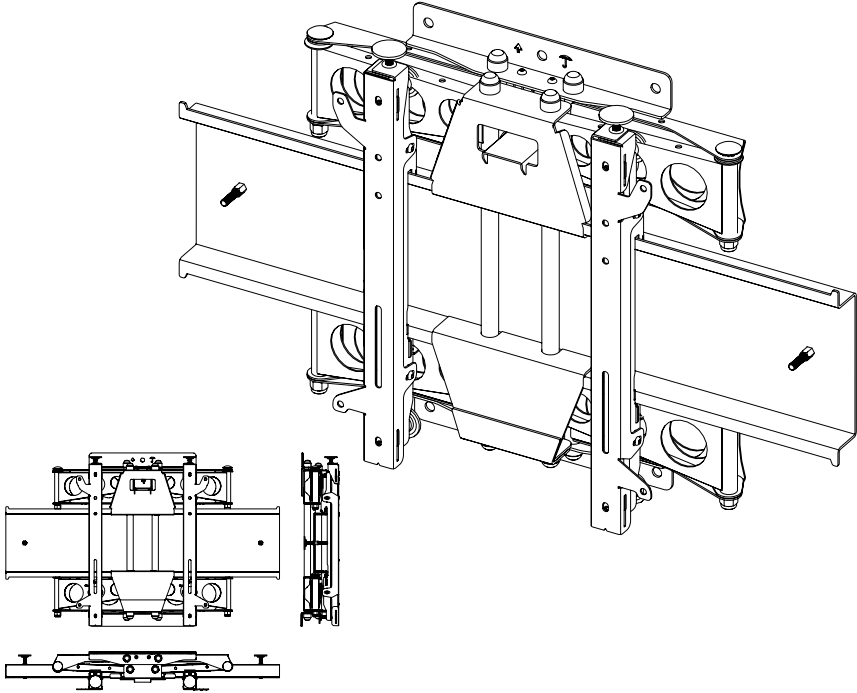

PLA4



Screen Size: 71 - 110" | **Guide Max. Weight:** 130kg

Please check model specific details before installing

Revised 26/04/24

WARNING

Please carefully inspect the product before assembling. If you notice any apparent damage, call your carrier claims agent and do not continue the installation until it has been reviewed. Please watch for pinch points. Do not put your fingers between moveable parts. Do not tamper with or disassemble any spring loaded parts. Before installing, make sure that the supporting surface will support five times the combined load of the solution and the hardware. Never exceed the maximum load capacity. Please also layout all components to ensure that you have all of the required parts before proceeding (see BOM list on following page). Use of this product for anything other than its specified use may result in failure or personal injury. This product is intended for indoor use only. We recommend using a qualified trades person for installation. Use an assistant or lifting equipment to lift and position products.

For support, please call: +44 (0)1865 767676 or email: sales@unicol.com



#	TOOLS REQUIRED
1	Pozi Head Screwdriver

INSTALLERS REQUIRED
1-2

COMPONENTS

#	DESCRIPTION	QTY
1	PLA4 Bracket	1
2	Adjustable Mount Arms	2

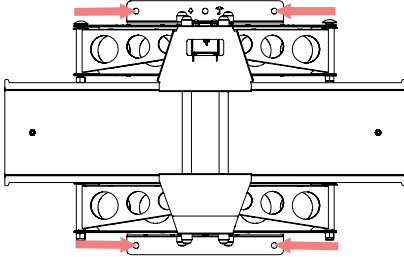

STEP 1

Using the identified mounting slots, fix the mount to the wall. Please note, the top of the mount can be identified by the up arrow and umbrella symbol.

Please consider cabling and wall fixings prior to installation. Please check surface is capable of supporting 5x the combined solutions weight.

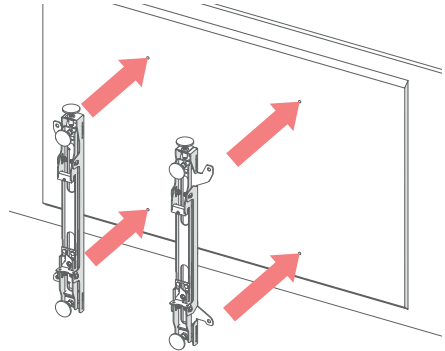

STEP 2

Utilising the fixing pack provided with your mount, attach the arms to the back of your screen.

Ensure the arms are the correct way up before tightening - the 'hook' part of the arm should be at the top.

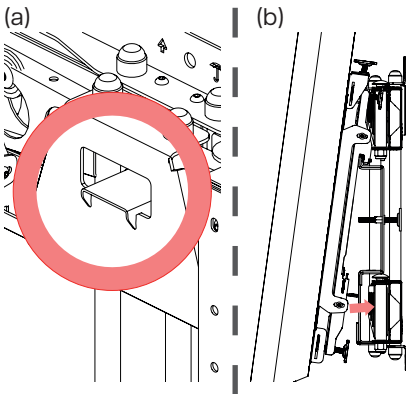

STEP 3

Make sure that the bracket is fully closed and secured via the latch at the top of the bracket (a).

Using another team member, lift the screen up and gradually offer it up to the back plate. Gently tilting the screen forward, hook the arms over the lip of the back plate (b) and lower once in position.



STEP 4

To access the rear of the screen, gently pull down on the pull cord (pre-installed) to unlock the latch at the top of the bracket. This will allow you pull the screen out from the wall and provide additional access behind the screen.

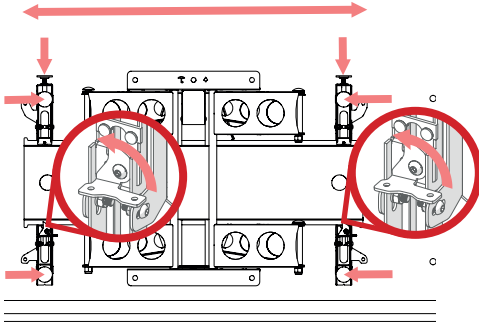

STEP 5

Centre the screen horizontally by sliding from side to side until you are happy with the position. Lock the arms in place by turning the locking lever 90° - as shown in the close ups within the red circles.

For fine adjustment (up/down and in/out) use the hand adjustable screws on each arm. Make micro adjustments to ensure the screen is level.

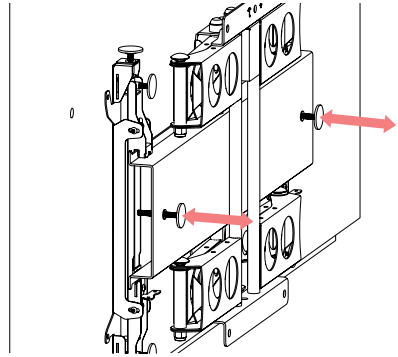

STEP 6

Once all adjustments are done, push the screen back into position until the latch clicks into place. Adjust the stability screws at the back of the screen mount so that they touch the wall when the bracket is fully closed and latched. This prevents the screen from moving if touched or knocked on the far left or right edges.