

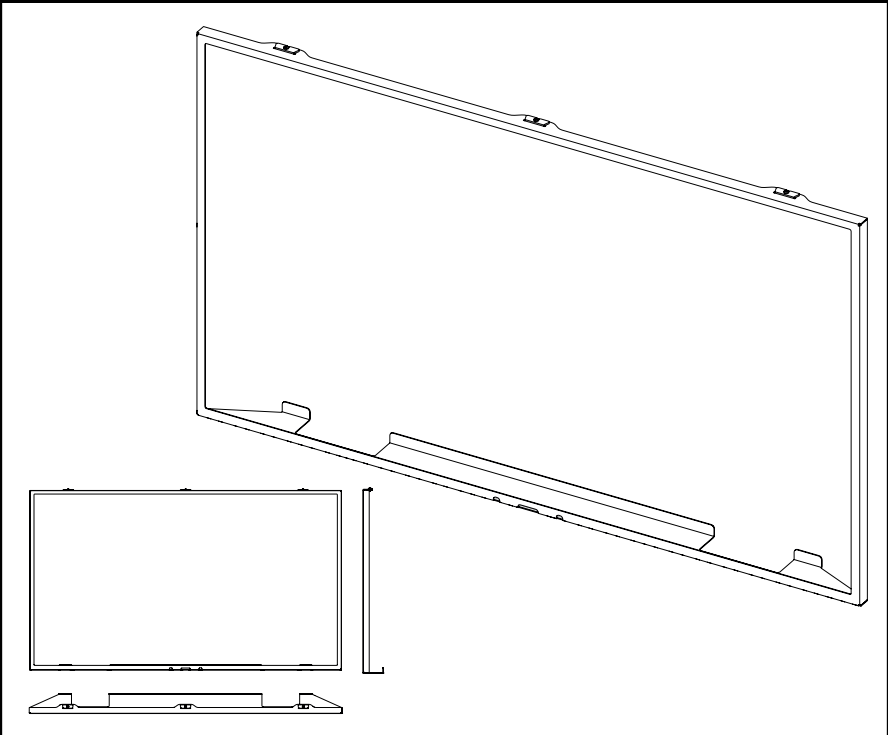

Clip-On Protective Covers PCLO / PCL1 / PCL2 / PCP0 / PCL1 / PCL2



Screen Size: 15 - 70" | **Guide Max. Weight:** n/a

Please check model specific details before installing

Revised 15/12/23

WARNING

Please carefully inspect the product before assembling. If you notice any apparent damage, call your carrier claims agent and do not continue the installation until it has been reviewed. Please watch for pinch points. Do not put your fingers between moveable parts. Do not tamper with or disassemble any spring loaded parts. Before installing, make sure that the supporting surface will support five times the combined load of the solution and the hardware. Never exceed the maximum load capacity. Please also layout all components to ensure that you have all of the required parts before proceeding (see BOM list on following page). Use of this product for anything other than its specified use may result in failure or personal injury. This product is intended for indoor use only. We recommend using a qualified trades person for installation. Use an assistant or lifting equipment to lift and position products.

For support, please call: +44 (0)1865 767676 or email: sales@unicol.com



#	TOOLS REQUIRED
1	Pozi Head Screwdriver

INSTALLERS REQUIRED
1-2

COMPONENTS

#	DESCRIPTION	QTY
1	Dedicated Protective Cover	1
2	Appropriate Fixing Clips	-
3	Appropriate Pozi Head Fixings	-

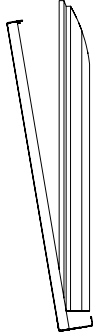

STEP 1

Offer the protective cover up to the bottom of the screen, ensuring that it starts to hook over the back of the screen.

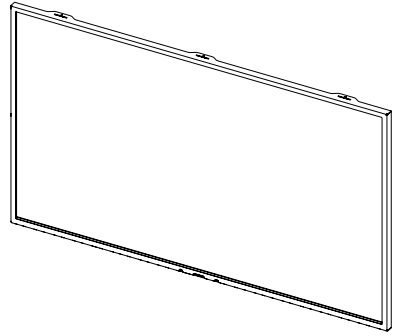

STEP 2

Once hooked over the bottom, gently push the top of the protective cover until it has covered the top of the screen.

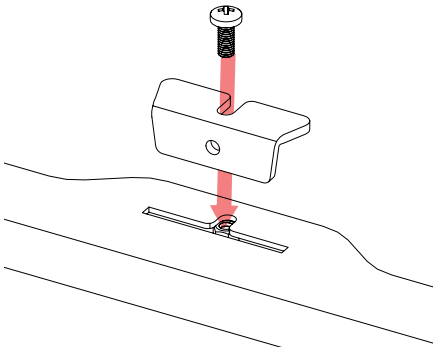

STEP 3

Place the clips into the slots located at the top of the protective cover, and screw into position. Repeat for the remaining slots across the top of the cover.

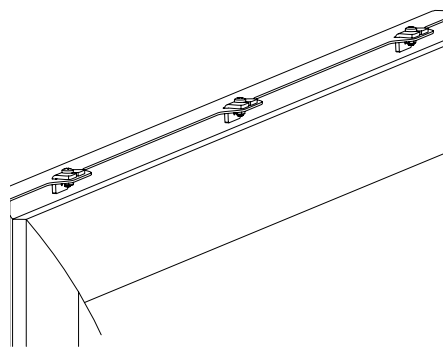

STEP 4

Ensure all clips are fully fastened and that cover is on securely.

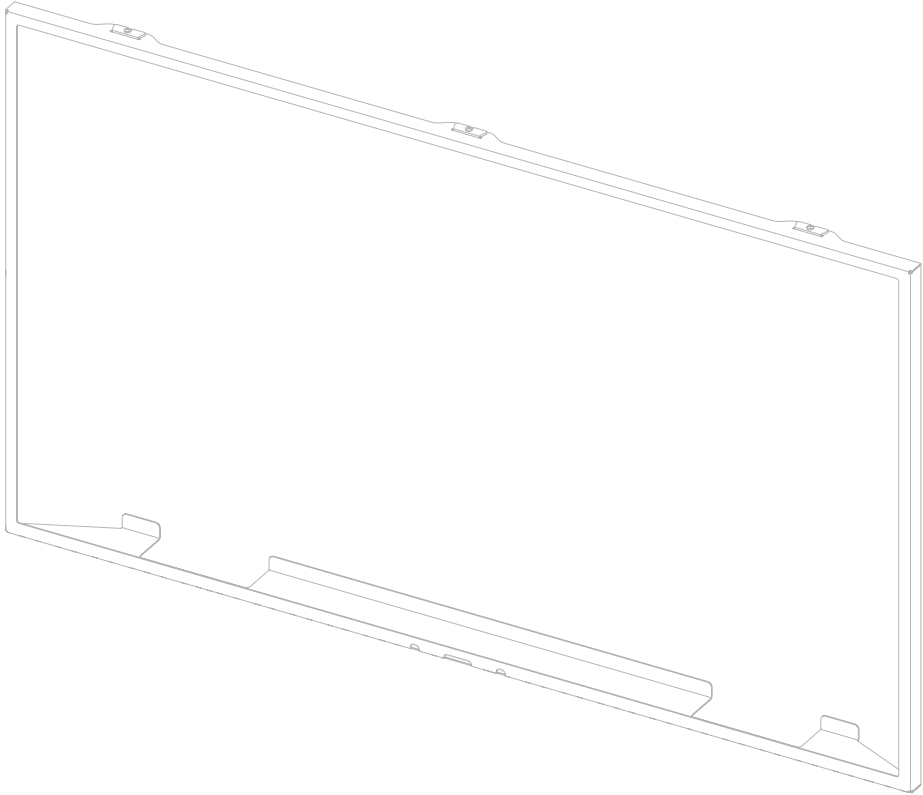

Any Questions?

+44 (0)1865 767676

sales@unicol.com

unicol.com/instructions