

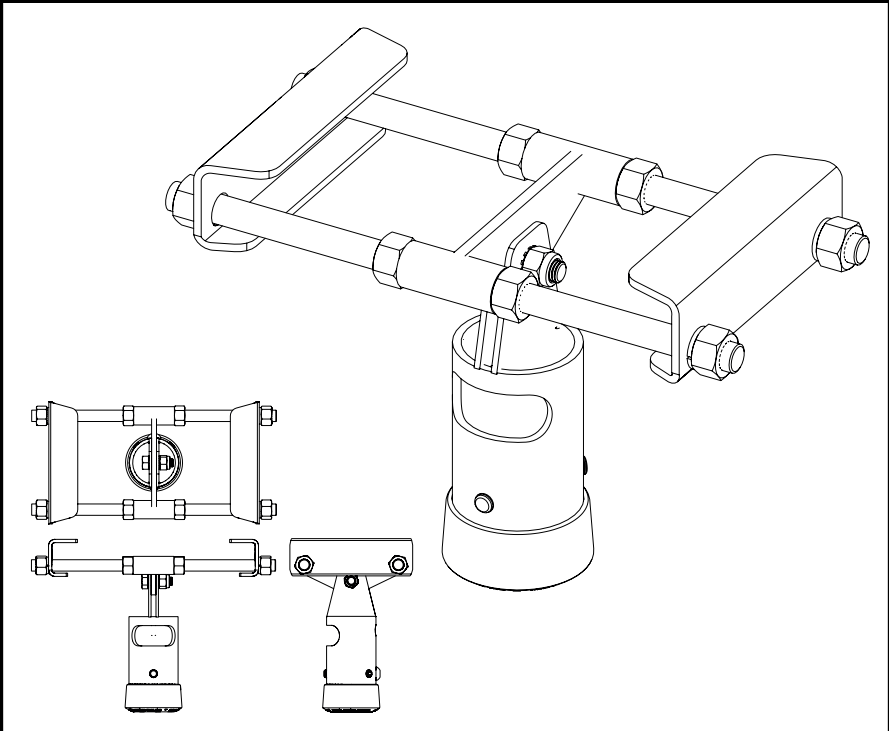

GC25 / GC35



Screen Size: n/a | Guide Max. Weight: 120kg

Please check model specific details before installing

Revised 05/01/24

WARNING

Please carefully inspect the product before assembling. If you notice any apparent damage, call your carrier claims agent and do not continue the installation until it has been reviewed. Please watch for pinch points. Do not put your fingers between moveable parts. Do not tamper with or disassemble any spring loaded parts. Before installing, make sure that the supporting surface will support five times the combined load of the solution and the hardware. Never exceed the maximum load capacity. Please also layout all components to ensure that you have all of the required parts before proceeding (see BOM list on following page). Use of this product for anything other than its specified use may result in failure or personal injury. This product is intended for indoor use only. We recommend using a qualified trades person for installation. Use an assistant or lifting equipment to lift and position products.

For support, please call: +44 (0)1865 767676 or email: sales@unicol.com



#	TOOLS REQUIRED
1	3/16th Allen Keys
2	17mm Spanner
3	19mm Spanner

INSTALLERS REQUIRED
1-2

COMPONENTS

#	DESCRIPTION	QTY
1	Girder Clamp Body	1
2	Girder Clamp End Plates	2
3	Spare Fixings	1

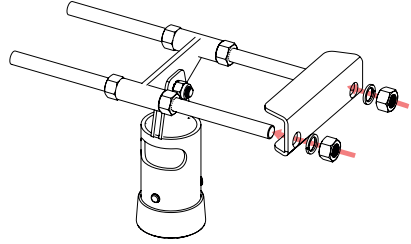
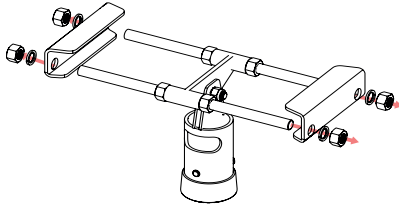

STEP 1

The GC25 and GC35 will be packaged fully assembled. To start, simply unscrew the two end plates and remove, leaving the bolts and suspension socket in the middle.

STEP 2

Hold the mount up to the girder and fit the first end plate over the edge and back onto the bolts, securing loosely to begin with.

Hold up the other end and slide the other end plate over the girder edge and through the bolts. Tighten on both sides until securely clamped over the girder.

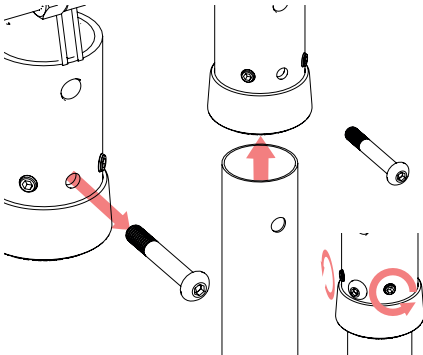

STEP 3

Remove the through-bolt from the socket and push your column length (*sold separately*) into place. Ensure that the through-bolt hole in the column is aligned with the hole in the socket.

Replace the through-bolt and tighten the grub screws at the side of the socket.

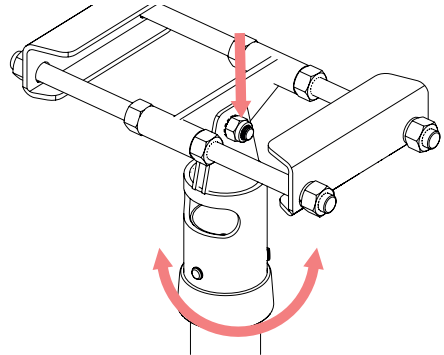

STEP 4

To adjust the angle of the installation, slightly loosen the nuts on the side of the socket. This will allow you to adjust the angle as necessary. Tighten when installation sits in the correct position.

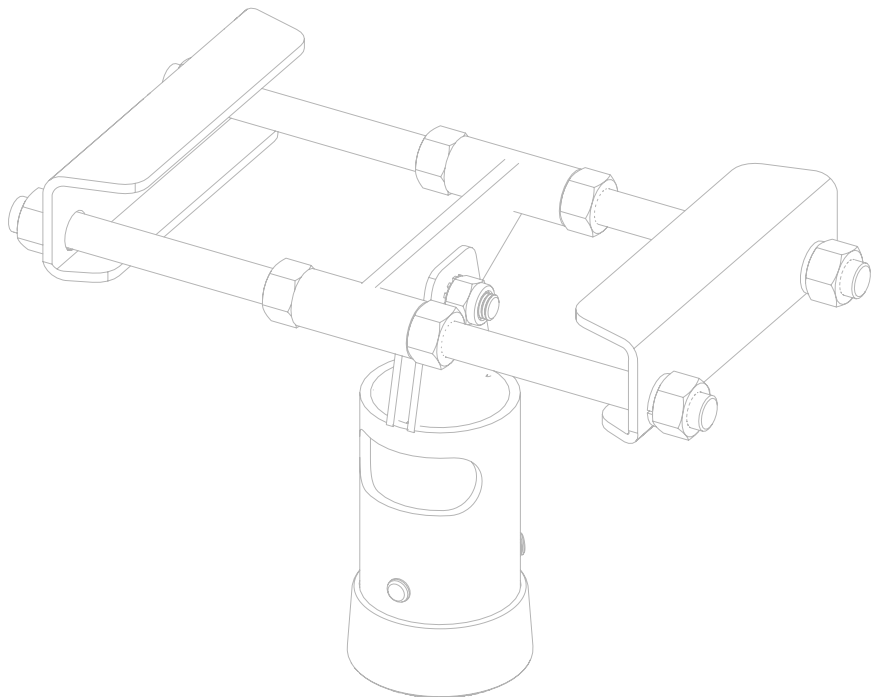

Any Questions?

+44 (0)1865 767676

sales@unicol.com

unicol.com/instructions