

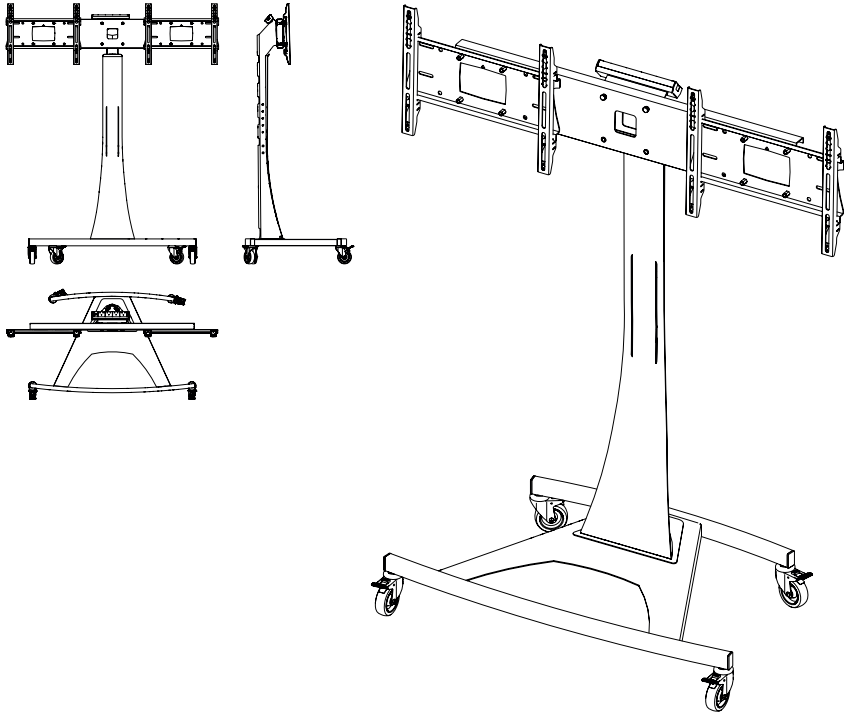

AXC15T / AXC15P



Screen Size: 33 - 57" | **Guide Max. Weight:** 35kg per screen

Please check model specific details before installing

Revised 05/01/24

WARNING

Please carefully inspect the product before assembling. If you notice any apparent damage, call your carrier claims agent and do not continue the installation until it has been reviewed. Please watch for pinch points. Do not put your fingers between moveable parts. Do not tamper with or disassemble any spring loaded parts. Before installing, make sure that the supporting surface will support five times the combined load of the solution and the hardware. Never exceed the maximum load capacity. Please also layout all components to ensure that you have all of the required parts before proceeding (see BOM list on following page). Use of this product for anything other than its specified use may result in failure or personal injury. This product is intended for indoor use only. We recommend using a qualified trades person for installation. Use an assistant or lifting equipment to lift and position products.

For support, please call: +44 (0)1865 767676 or email: sales@unicol.com



#	TOOLS REQUIRED
1	4mm & 5mm Allen Keys
2	Pozi Head Screwdriver
3	19mm Spanner
4	17mm Spanner

INSTALLERS REQUIRED
2

COMPONENTS

#	DESCRIPTION	QTY
1	1500mm Mast with Power Socket	1
2	Axia Trolley Base	1
3	Universal Mount Arms	4
4	Universal Mount Backplate	2
5	7.5cm Castors (2 standard, 2 braked)	4
6	Span Unit	1
7	M10 x 25 Button Head Screws	4
8	M10 x 20 Button Head Screws	4
9	Optional Extras inc. Locking Cabinet & Shelf	-

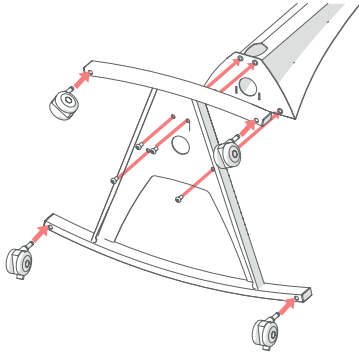

STEP 1

With mast laying flat on a table (as shown above) pick up the base with the help of another person and offer the base to the mast. Ensure fixing holes are aligned and then secure with M10x25 screws.

OPTIONAL: Locate the castors and push them into position (use a mallet if required). Ensure the 2 braked castors are located at the front.

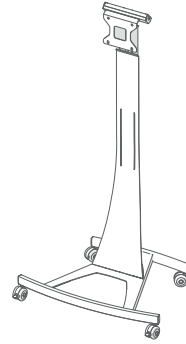

STEP 2

Once secure, stand the stand/trolley upright and place on a flat, stable surface. If building the trolley version shown, lock the brakes located on the front castors to prevent movement. Attach the 4-way power socket.

**Electrical socket instructions supplied separately*

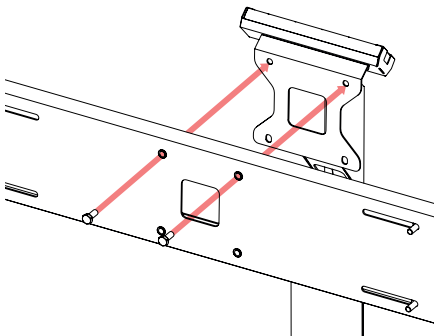

STEP 3

Line the span unit up with the 150x150mm centre holes at the top of the mast. Fix into place by bolting in the top two holes first.

[Fix any sound bar or video conference mounts now]

Place bolts into the bottom two holes and secure into place.

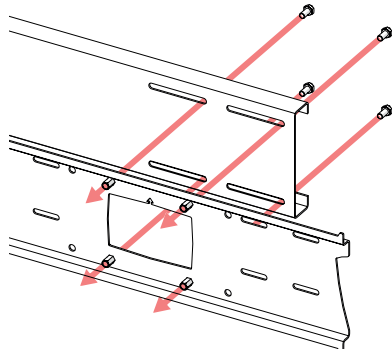

STEP 4

Line the back plate up with the span unit, as shown above. Fix 4x M10x20 screws from behind the mount adapter and into the 4 rivet nuts located on the back plate. Ensure back plate is secure and screws are tightened. This can be adjusted later. Repeat for the other side.

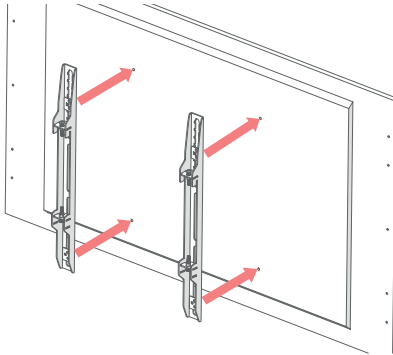

STEP 5

Locate the mounting holes on the back of your screen. Line the two mounting arms up (position arm hooks at the top of the screen) and using the tag locks and manufacturer recommended screws provided, attach the arms to the screen.

Unwind the bottom two fixing screws on the arms in preparation for next step.

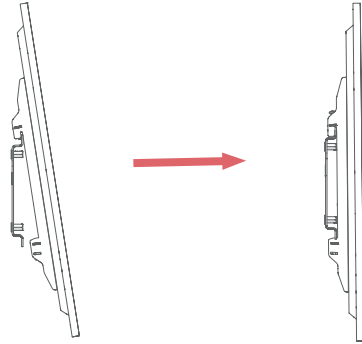

STEP 6

Using another team member, lift the screen up and gradually offer it up to the back plate. Gently tilting the screen forward, hook the arms over the lip of the back plate and lower once in position.

Centre the screen horizontally by sliding from side to side until you are happy with the position.

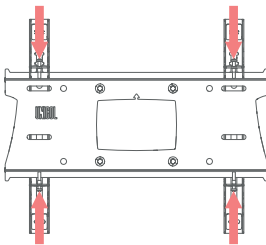

STEP 7

Once centred, ensure the bottom screws are not screwed tight and screw down the top screws to level the screen. Once level tighten bottom screws to secure the mount. Note that you won't be able to adjust the screen position after the screws have been tightened.

Repeat 7 - 9 for the second screen.

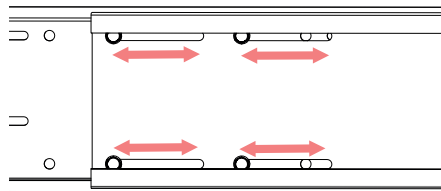

STEP 8

This step will require two people.

Once both screens are secure on the backplate, gently slide the screen and backplate from left to right as required on the span bar to centre both screens. Tighten fixings to secure.

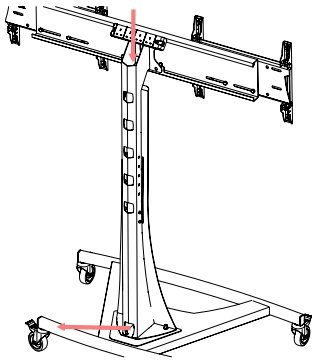

STEP 9

Using the 4-way socket for power and mast as a cable conduit, cable up your screen as shown above.

Your solution is now ready to go!

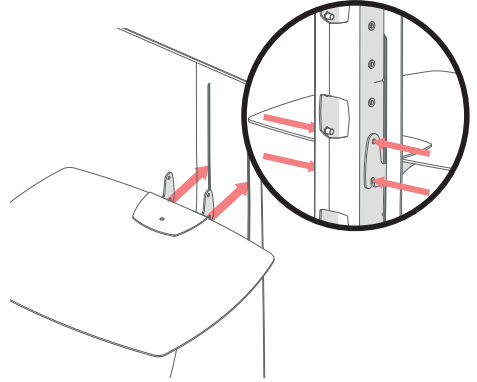

STEP 10 [OPTIONAL]

If using a shelf or locking cabinet, offer it up to the mast, sliding the 'arms' through the slits located in the centre of the mast.

Using the fixing points on the back of the mast, choose your designated height and screw into position.

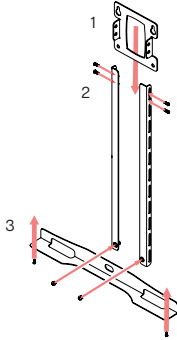

SBT GENERAL ASSEMBLY INSTRUCTIONS

Connect your device to mount plate³. Each mount is dedicated to your device so may vary from the image above.

Connect rails² to mount unit¹. To adjust sound bar height, simply fix in the slots that best suit.

Connect the mount plate³ to the bottom of the rails².

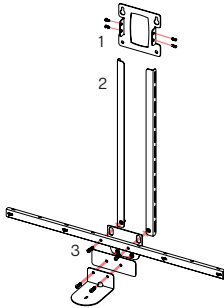

VCTST GENERAL ASSEMBLY INSTRUCTIONS

Connect your device to mount plate³. Each mount is dedicated to your device so may vary from the image above.

Connect rails² to mount unit¹. To adjust sound bar height, simply fix in the slots that best suit.

Connect the mount plate³ to the bottom of the rails².

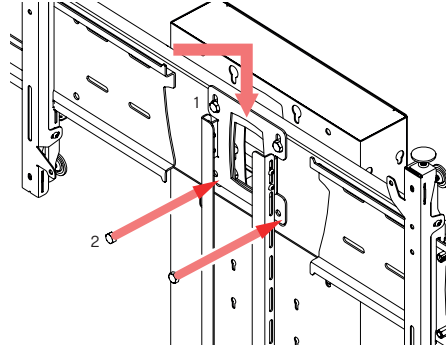

SBT

The SBT fixes to the 4x 150x150mm centre holes on the mast of some stands/trolleys. In some cases, this may include a span bar unit. In this instance, screens will need removing along with the bottom two fixings.

Loosen the top two fixings and slot the SBT tear-drop holes over the bolts¹. Line up the bottom two holes, and secure fixings into place². Tighten all fixings.

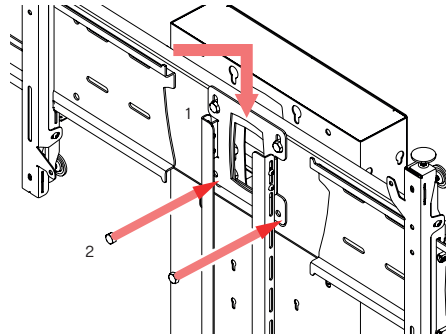

VCTST

The VCTST fixes to the 4x 150x150mm centre holes on the mast of some stands/trolleys. In some cases, this may include a span bar unit. In this instance, screens will need removing as well as the bottom two fixings.

Loosen the top two fixings and slot the VCTST tear-drop holes over the bolts¹. Line up the bottom two holes, and secure fixings into place². Tighten all fixings.

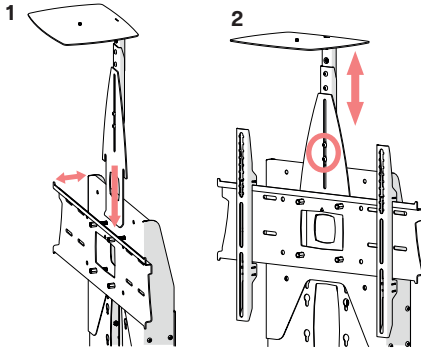

VCM1 / VCMT

1. The VCM can be fitted above or below the screen. It sits between mast and mount, slotting over the top 2 bolts that attach the screen mount to the stand. Loosen these bolts, slot the VCM in and tighten bolts.

2. Adjust the height of the platform by loosening the 2 screws highlighted and tightening when in position. Fix your VC camera to the platform to finish.

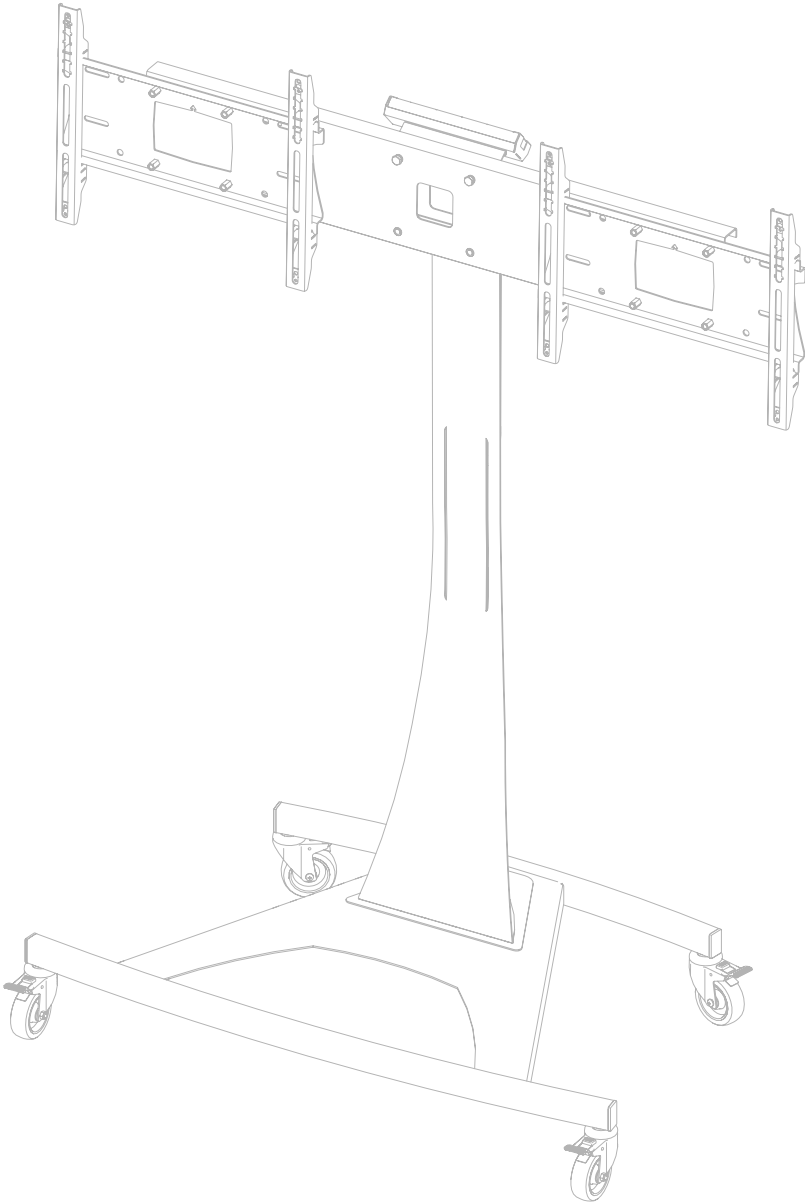

Any Questions?

+44 (0)1865 767676

sales@unicol.com

unicol.com/instructions