

BOM Table			
NO	Part Number	Description	QTY.
1	ASS--20063365	Pedestal stand screen mount 150X150	1
2	ASS--20063366	Fids Stainless steel bolt down column	1
3	Ass--20015085	Xactmatch Tilting Mount PLW Aqualite Aqlh-55	1
4	HMS-MET-10X25-SS-SC	Hex Machine Screw M10 X 25 (Stainless Self Colour)	4

Description		Tilted Fids Totem Mount 55 Inch Landscape	
UNLESS OTHERWISE SPECIFIED: DIMENSIONS ARE IN MILLIMETERS	Created By: Tim Smith	Material:	See Below - Special Notes
	Unicol Engineering Green Road Oxford OX3 8EU	Gauge:	
SURFACE FINISH: Powder Coated		DRW - REV REV -	Note: All Parts to be stainless steel
		Part Number & Part Revision	ASS--20063364 REV -

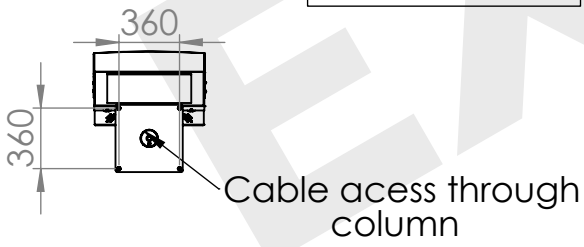
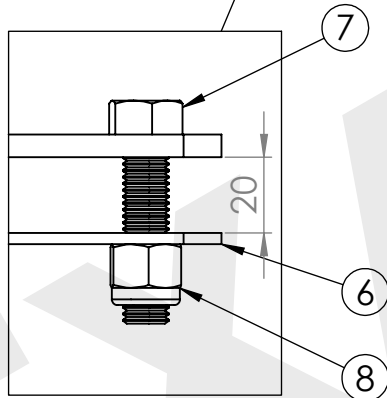
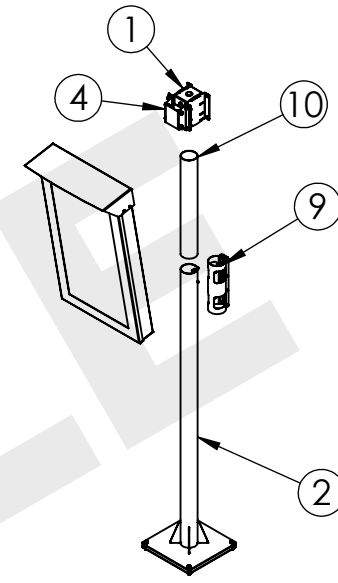
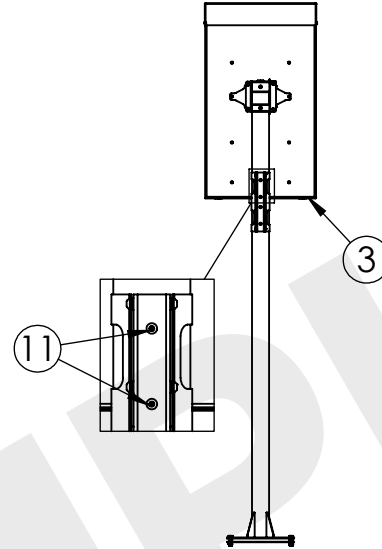
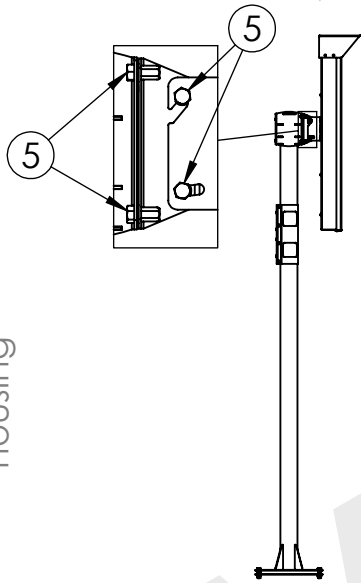
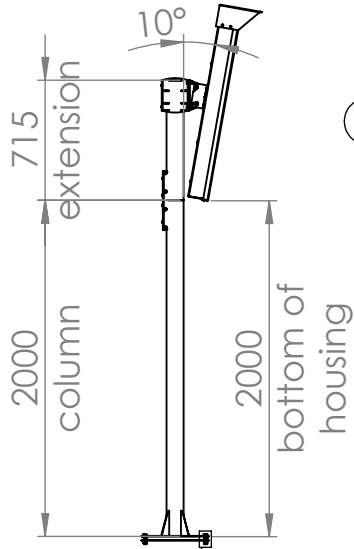
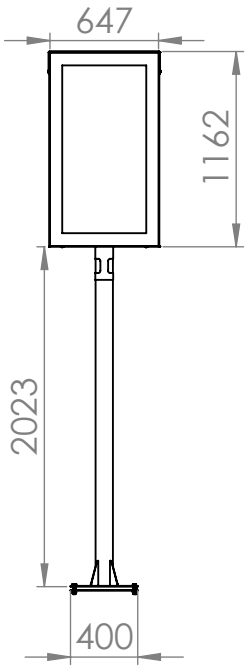

BOM Table			
NO	Part Number	Description	QTY.
1	ASS--20064489	FIDS Stand screen mount 150X150 Fixings	1
2	ASS--20064490	FIDS Mild steel bolt down column	1
3	ASS--20064373	Hisense single led panel portrait housing only	1
4	ASS--20064491	FIDS Led housing column mount adapter	1
5	HMS-MET-10X20-HT-BO	Hex Machine Screw M10 X 20 (High Tensile Black Oxide)	8
6	PAR--2070665	FIDS Mild steel column clamp plate	1
7	HMS-MET-12X50-HT-CZN	Hex Machine Screw M12 X 50 (High Tensile Bright Zinc Plated Clear Passivated)	4
8	NN-MET-12-HT-CZN	Nyloc (Nylon Insert) Nuts M12 (High Tensile Bright Zinc Plated Clear Passivated)	4
9	ASS--20064496	FIDS Stand column joiner	1
10	ASS--20064499	FIDS 4 Inch mild steel column extension 715mm	1
11	BH-MET-8X40-HT-BO	Button Head Screw M8 X 40 (High Tensile Black Oxide)	4

Description		FIDS Hisense ISE LED Stand	
UNLESS OTHERWISE SPECIFIED: DIMENSIONS ARE IN MILLIMETERS	Saved Date: 20 January 2026	DRW - REV REV -	See Below - Special Notes
	Created Date: 20 January 2026		
SURFACE FINISH: Powder Coated	Bend Tool:		
Created By Tim Smith	Material:	Gauge:	Part Number & Part Revision ASS--20064488 REV -
	Unicol Engineering Green Road Oxford OX3 8EU		